

# TANK VENTS



## PRESSURE VACUUM PIPE AWAY

### SOUR EMISSION MODEL

- One piece body construction.
- Connection sizes from 2" - 12" ANSI standard.  
*Optional D.I.N. | B.S. | J.I.S. | A.P.I. | N.P.T. connections are special order.*
- Pressure weight settings from 0.4 - 32.0 oz/in<sup>2</sup>
- Vacuum weight settings from 0.4 - 32.0 oz/in<sup>2</sup>
- Ships with Pressure/Vacuum setting certification

### Performance and Quality

We stand by quality and reliability in our products. That is why our vents are individually hand calibrated at our factory. Each vent will receive a certification sheet showing the exact set point of the pressure valve, as well as the leak rate for the valve.

### High Pressure Models

High pressure models are spring assisted.

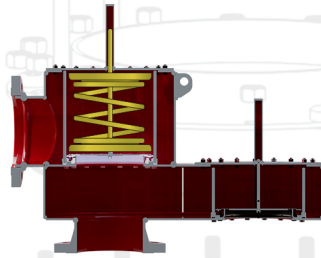

0.4 oz/in<sup>2</sup> setting is less than 0.14 SCFH for **ALL VENTS/ALL SIZES** at 90% of set point.

### Counter-Force Pallet

The inflating effect of the diaphragm increases as the pressure in the vent rises. This means that when the vent is closer to its set point, the seal is at its greatest performance.

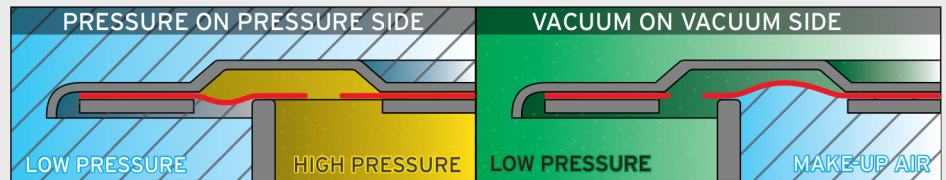

Self-Reinforcing Pressure Seal

Self-Cracking Vacuum Seal

• Available in: Carbon(SA516-70N), Stainless Steel(304L/310L) Aluminum, Hastelloy(C276)

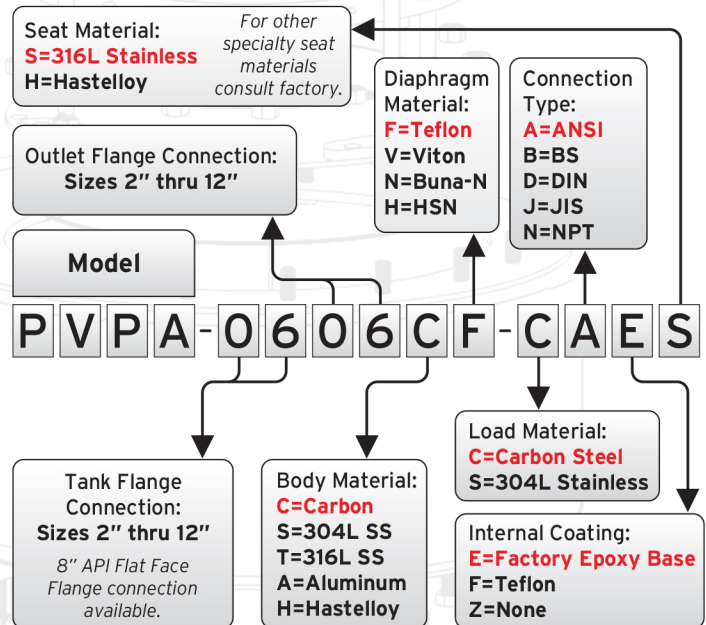
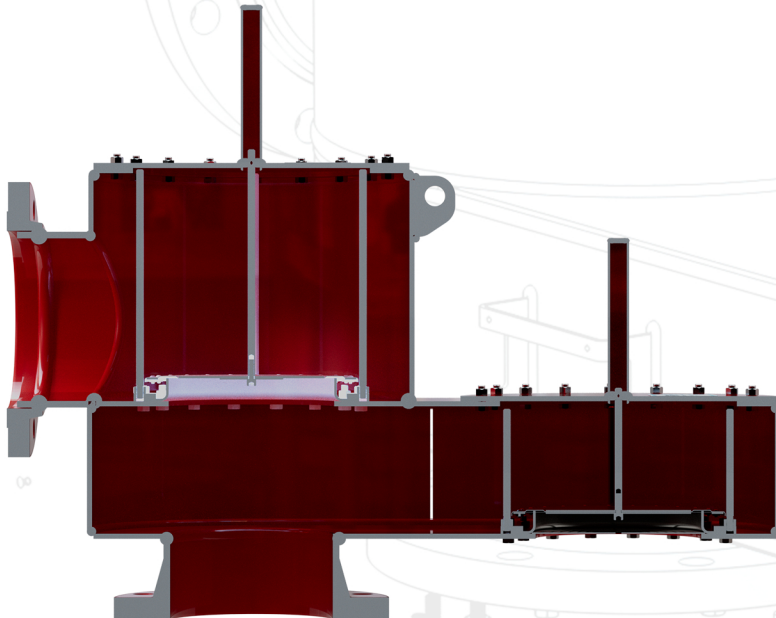

Example: The above order number indicates a Pressure/Vacuum vent with Pipe Away exhaust. Inlet is 6", Outlet is 6", Carbon Steel body, Teflon diaphragm, Weight loaded with Steel weight material, and Factory Epoxy Base Internal Coating.

Dimensions and Layout

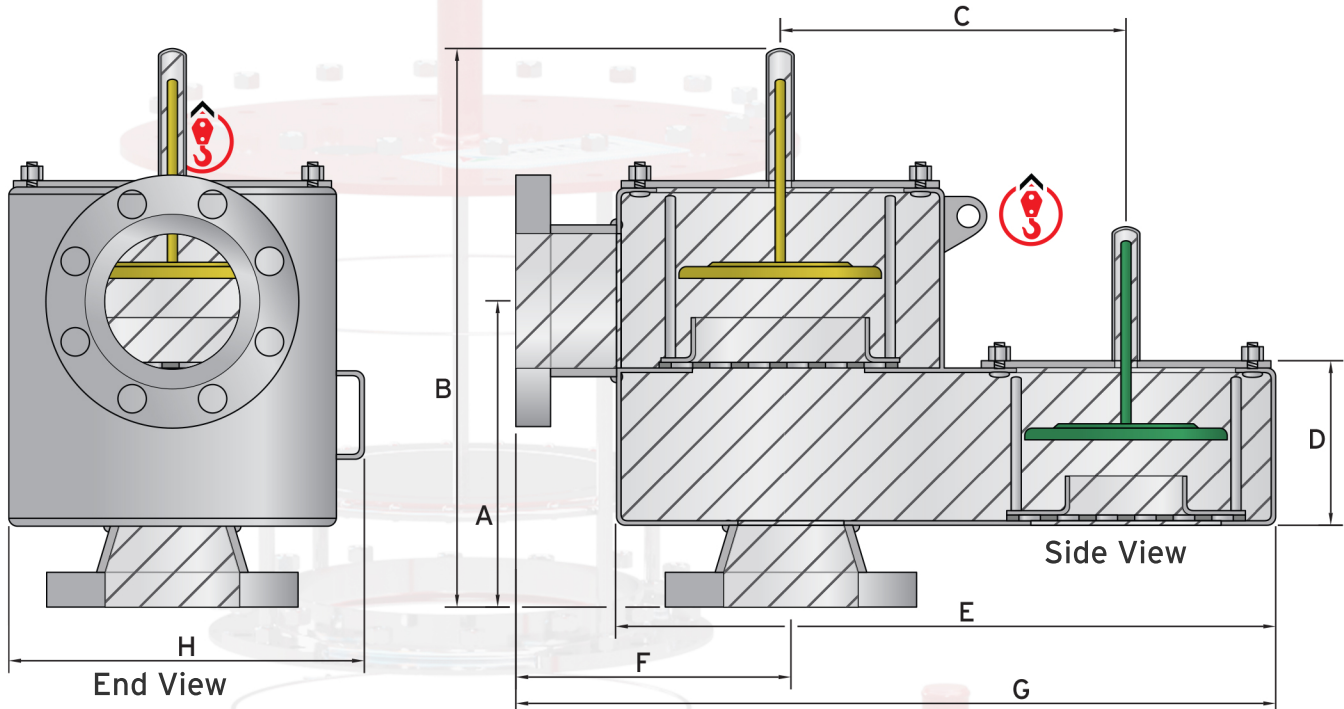

Dimensions and Weight

SIZE(in)	A	B	C	D	E	F	G	H
2	8"	16 3/4"	12 3/4"	4 1/2"	23 1/2"	8 3/8"	26 1/2"	12 3/16"
3	8 3/4"	17"	12 3/4"	4 1/2"	23 1/2"	8 3/8"	26 1/2"	12 3/16"
4	9 15/16"	18 1/2"	12 3/4"	5"	23 1/2"	8 3/8"	26 1/2"	12 3/16"
6	12"	22 5/16"	16"	5 1/2"	30"	10"	33"	15 11/16"
8	14 7/16"	27 9/16"	18"	6 1/2"	34"	12"	38"	17 11/16"
10	16 7/16"	31 3/8"	20"	7 1/2"	38"	13"	42"	19 11/16"
12	18 15/16"	36 3/8"	22"	8 1/2"	42"	14"	46"	21 11/16"

SIZE(in)	A	B	C	D	E	F	G	H
2x3	8 1/2"	16 3/4"	12 3/4"	4 1/2"	23 1/2"	8 3/8"	26 1/2"	12 3/16"
3x4	9 3/16"	17"	12 3/4"	4 1/2"	23 1/2"	8 3/8"	26 1/2"	12 3/16"
4x6	11"	20 1/2"	12 3/4"	5"	23 1/2"	8 3/8"	26 1/2"	12 3/16"
6x8	12 15/16"	22 5/16"	16"	5 1/2"	30"	11"	34"	15 11/16"
8x10	15 7/16"	27 9/16"	18"	6 1/2"	34"	12"	38"	17 11/16"
10x12	17 7/16"	31 3/8"	20"	7 1/2"	38"	13"	42"	19 11/16"

Flow Curve Charts

**VC-PVPA**  
Vapour Control

[www.prismcorp.net](http://www.prismcorp.net)