

# TANK VENTS



## VACUUM ONLY SIDEMOUNT

### INTAKE MODEL

- One piece body construction.
- Connection sizes from 2" - 12" ANSI standard.  
*Optional D.I.N. | B.S. | J.I.S. | A.P.I. | N.P.T. connections are special order.*
- Vacuum weight settings from 0.4 - 32.0 oz/in<sup>2</sup> PSIG
- Ships with Vacuum setting certification

### Performance and Quality

We stand by quality and reliability in our products. That is why our vents are individually hand calibrated at our factory. Each vent will receive a certification sheet showing the exact set point of the pressure valve, as well as the leak rate for the valve.

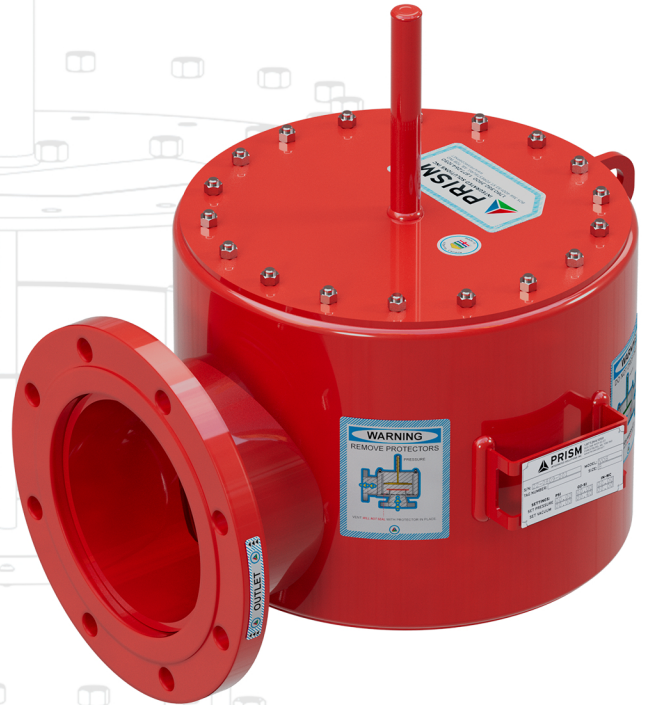

0.4 oz/in<sup>2</sup> setting is less than 0.14 SCFH for **ALL VENTS/ALL SIZES** at 90% of set point.

### Counter-Force Pallet

The inflating effect of the diaphragm increases as the vacuum in the vent rises. This means that when the vent is closer to its set point, the seal is at its greatest performance.

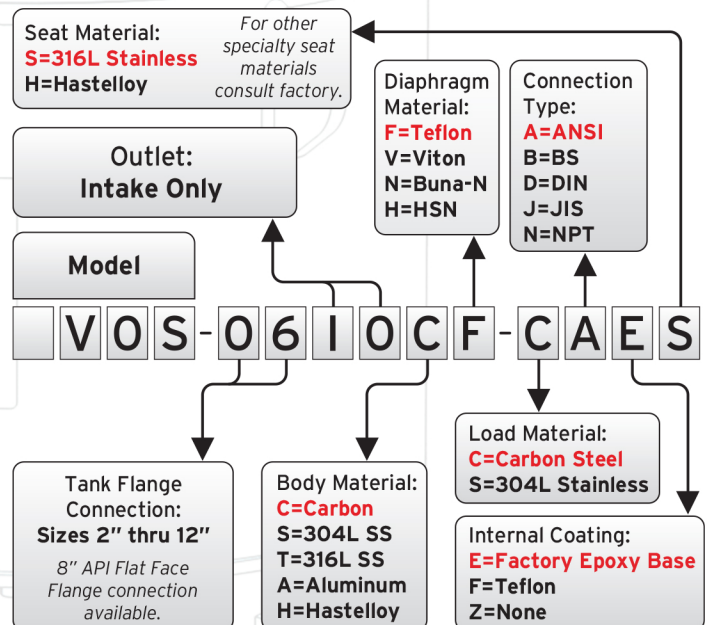
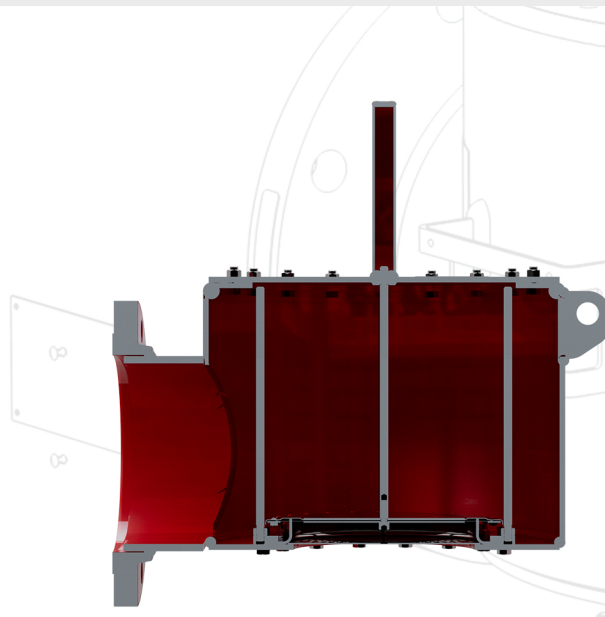
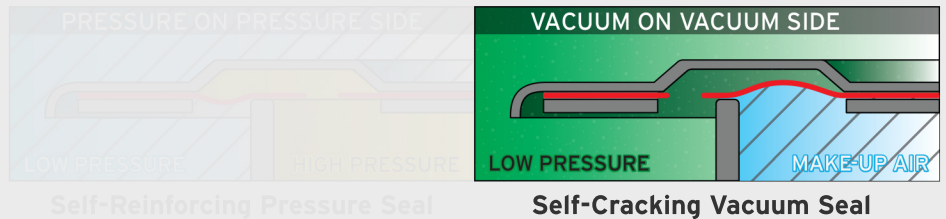

• Available in: Carbon(SA516-70N), Stainless Steel(304L/310L) Aluminum, Hastelloy(C276)

Example: The above order number indicates a Vacuum Only vent intake. Inlet is 6", Carbon Steel body, Teflon diaphragm, Weight loaded with Steel weight material, and Factory Epoxy Base Internal Coating.